

Fabrication of fine aggregate angularity apparatus and its application

Md. Saiful Islam, Md. Akib Hasan Basunia and Swapan Kumar Palit

*Department of Civil Engineering
Chittagong University of Engineering and Technology, Chittagong 4349, Bangladesh*

Received 12 September 2018

Abstract

Traffic volume is increasing in cities and suburbs day by day that causing more traffic loads on road pavement. Increasing magnitude of traffic loads and volume is causing premature rutting and undulation in flexible pavement. Rutting and permanent undulation are decreasing traffic speed, increasing journey time, causing passenger discomfort, increasing maintenance cost of both vehicles and roads. Rutting and permanent undulation have a correlation with aggregate angularity. It can be minimized by selecting fine aggregate having good fine aggregate angularity number while constructing pavement and this value having ranges from 43 to 45 showed good performance in resisting rutting and permanent undulation according to Nebraska Transportation Center, USA. In Bangladesh, fine aggregate angularity is not considered during pavement construction because of lacking suitable apparatus. The main purpose of the study is to determine fine aggregate angularity number of fine aggregate using a fabricated fine aggregate angularity apparatus. ASTM C-1252 and AASHTO T-304 have provided same manual for fabricating fine aggregate angularity test apparatus and test procedure to determine fine aggregate angularity which have been followed. Another attempt has been taken to find suitable fine aggregate sources for the construction of flexible pavement based on angularity test. From the study, it has been found that fine aggregate angularity number have been varied ranges from 44.15 to 50.2 for various sand samples collected from various sources. Only few samples have been found suitable for flexible pavement construction as fine aggregate angularity number of them lies between 43 to 45.

© 2018 Institution of Engineers, Bangladesh. All rights reserved.

Keywords: Rutting, permanent undulation, fine aggregate angularity number, uncompacted void content, fineness modulus.

1. Introduction

Transportation sector is very important for the development of a country. Now a day's highway is mostly used transportation media connecting localities. Highway engineers are facing newly arising problems with the rapid increase of roads and highway. Among them rutting and permanent undulation of roads and highway are some burning issues. Rutting and

permanent undulation have a correlation with aggregate angularity. This problem can be overcome by selecting the materials which have required characteristics such as gradation, fineness modulus, texture, shape of fine aggregate, angularity of fine aggregate etc. The uncompacted void of an aggregate is used as an indicator of fine aggregate angularity because aggregates with greater angularity should likewise have great uncompacted void contents values. There is clear evidence that good performing mixes can be designed with uncompacted void contents from 43% to 45% according to Chowdhury *et. al* (2001). The fine aggregate angularity apparatus accurately determines the uncompacted void content of fine aggregate samples. It indicates the angularity and sphericity of fine aggregate and its workability in a mixture. This apparatus is very rare in our country. As a matter of fact, conducting fine aggregate angularity test to determine the fine aggregate angularity of samples, AASHTO T-304 & ASTM C-1252 have provided same manual which is shown in Figure 1 & 2 along with various dimensions of the various parts. With this era of above study, the following objectives have been selected for this present work.

- (i) Fabrication of fine aggregate angularity test apparatus which meets AASHTO T-304 requirements.
- (ii) Determining uncompacted void content of fine aggregates collected from various sources.
- (iii) Determination of suitability of fine aggregate sources for the construction of flexible pavement based on angularity test.

Table 1
Locations of fine aggregate samples with specific gravity and fineness modulus

Sample no	Source name	Fineness Modulus (FM)	Specific Gravity
1	Sylhet Sand-1	2.53	2.60
2	Godaun, Raozan, Chittagong	1.8	2.62
3	Lelang khal, Fotikchori, Chittagong	1.45	2.63
4	Modunaghat, Hathajari, Chittagong	1.43	2.63
5	Lichubagan, Ranguniya, Chittagong	1.63	2.65
6	Padma river, Rajshahi	1.66	2.66
7	Chokoria, Cox's Bazar	1.60	2.64
8	Sylhet Sand-2	2.78	2.63
9	Baluchora, CUET	1.79	2.65
10	Sylhet Sand-3	2.66	2.62

1.1 Fine aggregate angularity (FAA)

Aggregate angularity can be defined as the measurement of the sharpness of the corners of particles. Fine Aggregate Angularity is the percent of air void present in loosely compacted fine aggregate. Aggregate particle shape form angularity and surface texture properties are shown in Figure 3. Rounded particles are low angularity and non-rounded particles are high angularity. It is a parameter of great importance in mix design of asphalt. Theoretically it can be defined as, (DAS, 2006)

$$\text{Aggregate angularity} = \frac{\text{average radius of coners and edges}}{\text{radius of maximum inscribe circle}} \quad (1)$$

Angularity is often mentioned as having the potential to influence aggregate and mixture performance through interaction with other properties. Angularity tests are used in asphalt mix design to ensure particle interlock and adequate void content. It is an indirect test which is measured by uncompacted void content test.

2. Methodology

To fulfill the objectives of the present investigation the total work flow has been shown in Figure 4.

2.1 Sample collection

For conducting FAA test samples of fine aggregate from several sources are needed. Hence good numbers of samples have been collected from different parts of Bangladesh. But importance is given on local sand sources. Collections of the samples have been done through different local construction sites, construction material sellers and friends from different localities. Their locations along with their specific gravity & fineness modulus have been shown in Table 1. The Grain Size Distribution (GSD) curves of the samples have also been depicted in Figure 5. From the curves, it is seen that only few samples named as Sylhet sand have been shown well graded aggregates.

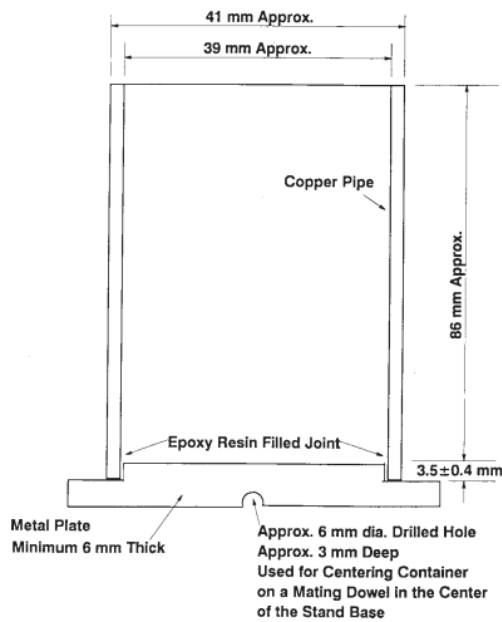

Fig. 1. Nominal 100-ml Cylindrical Measure.

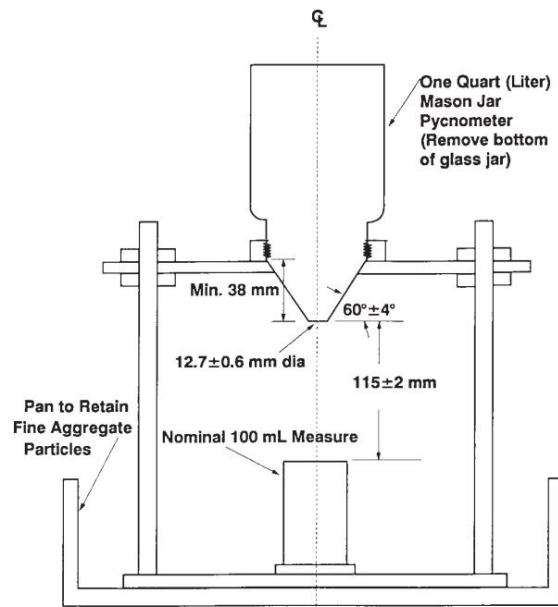

Fig. 2. Suitable Funnel Stand Apparatus with Cylindrical Measure in Place.

2.2 Calibration of cylinder

The instruction for calibration of cylinder according to AASHTO T-304 is given below. It is to be applied a light coat of grease to the top edge of the dry, empty cylindrical measure. Then o be Weighted the measure, grease, and glass plate & to be filled the measure with freshly boiled, deionized water at a temperature of 18 to 24°C. The temperature of the water to be recorded & the glass plate to be placed on the measure, being sure that no air bubbles remain. Then the outer surfaces of the measure to be dried and to be determined the combined mass of measure, glass plate, grease, and water by weighing. Following the final weighing, it is to be removed the grease and to be determined the mass of the clean, dry, empty measure for subsequent tests. The volume of the cylindrical measure is calculated using equation 2.

$$(AASHTO). V = \frac{1000M}{D} \quad (2)$$

Where, V = volume of cylinder, mL, M= net mass of water, gm, and D = density of water, kg/m³. Density of water is determined using AASHTO T 19. Then it is to be determined the

volume to the nearest 0.10 mL. If the volume of the measure is greater than 100.0 mL, it may be desirable to grind the upper edge of the cylinder until the volume is exactly 100.0 mL to simplify subsequent calculations. The fabricated cylinder has been calibrated and it has been shown 99.94 mL which is satisfied as per AASHTO T-304.

3. Experimental setup

One of the main objectives of this study is to conduct FAA test of fine aggregate. So an apparatus has been fabricated in the transportation engineering laboratory of Civil Engineering at CUET as it is not readily available in Bangladesh.

3.1 Fine aggregate angularity apparatus

The Fine Aggregate Angularity Apparatus is not a unit body apparatus. It consists of seven important parts. According to AASHTO T-304 components of the apparatus have been designed and fabricated which is shown in Figure 6. The ample discussion on the parts of the fine aggregate angularity test apparatus is provided in the subsequent paragraphs.

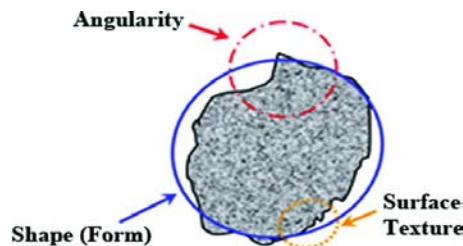

Fig. 3. Aggregate particle shape form, angularity and surface texture properties.

3.2 Cylindrical measure

A right cylinder of approximately 100 mL capacity having an inside diameter of approximately 39 mm and an inside height of approximately 86 mm made of brass, metal or drawn copper water tube meeting ASTM Specification B 88 Type M, or B 88 M Type C. The bottom of the measure shall be metal at least 6 mm thick, shall be firmly sealed to the tubing, and shall be provided with means for aligning the axis of the cylinder with that of the funnel. It has been shown in Figure 6 & dimensions have been shown in Figure 1.

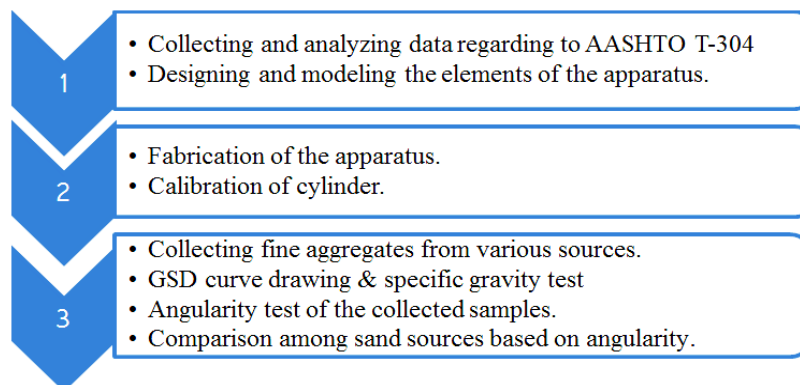

Fig. 4. Work flow diagram of present investigation.

3.3 Funnel

The lateral surface of the right frustum of a cone sloped $60 \pm 4^\circ$ from the horizontal with an opening of 12.7 ± 0.6 -mm diameter. The funnel section shall be a piece of metal, smooth on

the inside and at least 38 mm high. It shall have a volume of at least 200 mL or shall be provided with a supplemental glass or metal container to provide the required volume. It has been shown in Figure 6 & dimensions have been shown in Figure 2.

3.4 Funnel stand

A three- or four-legged support capable of holding the funnel firmly in position with the axis of the funnel co linear (within a 4° angle and a displacement of 2 mm) with the axis of the cylindrical measure. The funnel opening shall be 115 ± 2 mm above the top of the cylinder. A suitable arrangement has been shown in Figure 6 & dimensions have been shown in Figure 2.

3.5 Glass plate

A square glass plate approximately 60 by 60 mm with a minimum 4-mm thickness used to calibrate the cylindrical measure.

3.6 Pan

A metal or plastic pan of sufficient size is used to contain the funnel stand and to prevent loss of material. The purpose of the pan is to catch and retain fine aggregate particles that overflow the measure during filling and strike off.

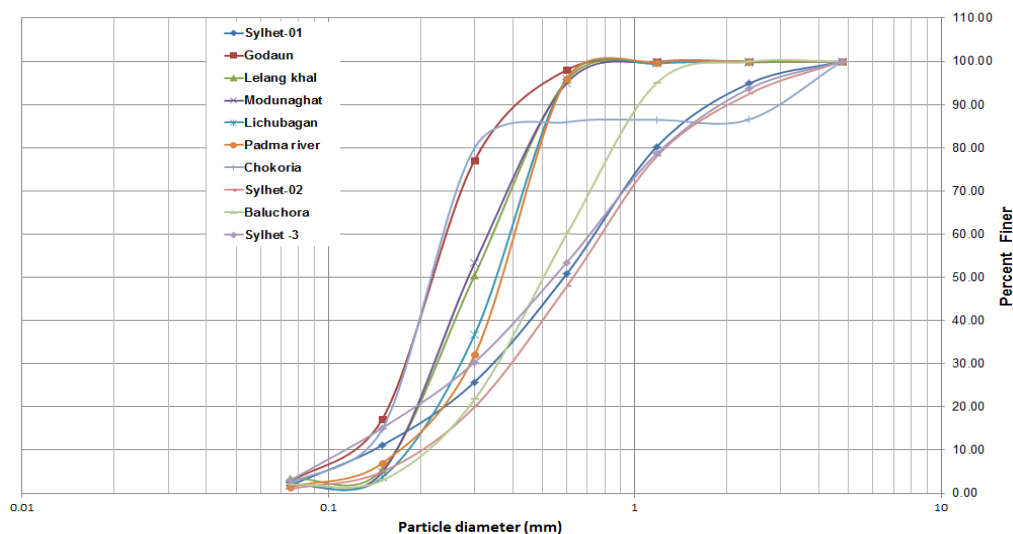

Fig. 5. Grain size distribution (GSD) curves of collected samples.

3.7 Metal spatula

Metal spatula is having a blade approximately 100 mm length, and at least 20 mm wide, with straight edges. The end shall be cut at a right angle to the edges. The straight edge of the spatula blade is used to strike off the fine aggregate.

3.8 Scale or balance

Scale or Balance should be accurate and readable to ± 0.1 g within the range of use, capable of weighing the cylindrical measure and its contents.

4. Preparation of test samples

Three methods are available for preparing test samples depending upon the aggregates size fractions. For Methods A and B, the samples have been washed over a $150\text{-}\mu\text{m}$ (No. 100) or

75- μm (No. 200) sieve in accordance with Test Method ASTM C-117 and then dried and sieved into separate size fractions in accordance with the procedures of Test Method ASTM C-136. It is to be maintained the necessary size fractions obtained from one (or more) sieve analysis in a dry condition in separate containers for each size. For Method C, a split of the as received samples has been dried in accordance with the drying procedure in Test Method ASTM C-136. Each test method has different test combination of sand samples, which are given below.

4.1 Test method A

Standard Graded Sample— it is to be weighted out and combined the following quantities of fine aggregate which have been dried and sieved in accordance with Test Method ASTM C-136. Table 2 shows the fraction of sample used in method A. The tolerance on each of these amounts is ± 0.2 gm.

Table 2
Fraction of sample used in Method A

Individual Size Fraction	Mass, gm
2.36 mm (No. 8) to 1.18 mm (No. 16)	44
1.18 mm (No. 16) to 600 μm (No. 30)	57
600 μm (No. 30) to 300 μm (No. 50)	72
300 μm (No. 50) to 150 μm (No. 100)	17
Total	190 gm

4.2 Test method B

Individual Size Fractions— it is to be prepared a separate 190 gm sample of fine aggregate, dried and sieved in accordance with Test Method ASTM C-136, for each of the following size fractions shown in Table 3. The tolerance on each of these amounts is ± 1 gm. These samples have not been mixed together. Each size is tested separately.

Table 3
Fraction of sample used in Method B

Individual Size Fraction	Mass, gm
2.36 mm (No. 8) to 1.18 mm (No. 16)	190
1.18 mm (No. 16) to 600 μm (No. 30)	190
600 μm (No. 30) to 300 μm (No. 50)	190

4.3 Test method C

As Received Grading— The sample is to be passed (dried in accordance with Test Method ASTM C-136) through a 4.75-mm (Sieve No. 4) sieve & to be obtained a 190 ± 1 gm sample of the material passing the 4.75-mm sieve for test.

5. Test procedure

Test sample has been mixed each with the spatula until it appears to be homogeneous. The jar and funnel section are positioned in the stand and the cylindrical measure is centered as shown in Figure 2. A finger is used to block the opening of the funnel. The test sample has been poured into the funnel. The material in the funnel has been leveled with the spatula. The finger has been removed and the sample has been allowed to fall freely into the cylindrical measure. A test progress has been shown in Figure 7. After the funnel empties, excess heaped fine aggregates have been stroked off from the cylindrical measure by a single pass of the

spatula with the width of the blade vertical using the straight part of its edge in light contact with the top of the measure. Until this operation is complete, it is to be taken care to avoid vibration or any disturbance that could cause compaction of the fine aggregate in the cylindrical measure. Adhering grains have been brushed from the outside of the container and the mass of the cylindrical measure and contents has been measured to the nearest 0.1 gm. All fine aggregate particles have been retained for a second test run. The sample has been recombined from the retaining pan and cylindrical measure and the procedure has been repeated. It is to be averaged the results of two runs. The mass of the empty measure has been recorded. Also, for each run, it is to be recorded the mass of the measure and fine aggregates. The uncompacted void has been calculated for each determines using equation 3.

$$U = \frac{V-(F/G)}{V} \times 100 \quad (3)$$

Where, V=volume of cylindrical measure, mL, F=net mass of fine aggregate in measure, gm (gross mass minus the mass of the empty measure), G=dry relative density (specific gravity) of fine aggregate and U= uncompacted voids in the material, %.

For the standard graded sample (Test Method A), it is to be calculated the average uncompacted voids for the two determinations and to be reported the results as U_s .

Table 4
Comparison of angularity number among the collected samples

Serial No.	Source Name	Gradation Observed	Angularity Number	Suitable Test Method
1	Sylhet Sand-1	Well graded	45.06	Method C
2	Godaun, Raozan, Chittagong	Uniform graded	46.45	Method C
3	Lelang khal, Fotikchori, Chittagong	Uniform graded	48.12	Method C
4	Modunaghat, Hathajari, Chittagong	Uniform graded	49.2	Method C
5	Lichubagan, Rangunia, Chittagong	Uniform graded	47.6	Method C
6	Padma river, Rajshahi	Uniform graded	48	Method C
7	Chokoria, Cox's Bazar	Uniform graded	50.2	Method C
8	Sylhet Sand-2	Well graded	44.15	Method C
9	Baluchora, CUET	Semi well graded	44.97	Method C
10	Sylhet Sand-3	Well graded	45.02	Method C

For the individual size fractions (Test Method B), First, the average uncompacted voids for the determinations made on each of the three size-fraction samples:

U_1 = uncompacted voids, 2.36 mm (No. 8) to 1.18 mm (No. 16), %,

U_2 = uncompacted voids, 1.18 mm (No. 16) to 600 μ m (No. 30), %, and

U_3 = uncompacted voids, 600 μ m (No. 30) to 300 μ m (No. 50), %

Second, the mean uncompacted void (U_m) for all three sizes is calculated using equation 4.

$$U_m = (U_1+U_2+U_3) / 3 \quad (4)$$

For the as-received grading (Test Method C), the average uncompacted void is to be calculated for the two determinations and to be reported the result as U_R .

6. Experimental investigation

Ten fine aggregate samples have been collected from different parts of Bangladesh. Experimental investigation includes the determination of FAA number for the collected

samples. It is seen that only well graded samples of collected samples have been qualified for performing all the methods specified by AASHTO T304 as all fraction of particles are available in the samples. As method C can be done for all the collected samples, So comparison of FAA number has been made among all the samples on the basis of method C specified by AASHTO T304. The results of FAA number of all collected samples are summarized in Table 4.

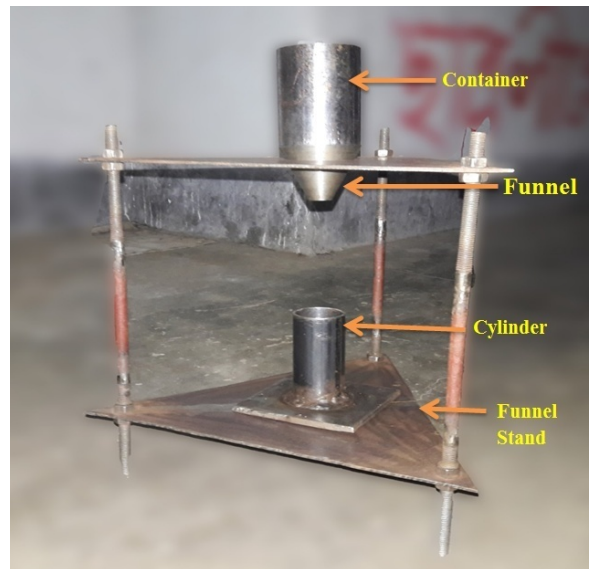

Fig. 6. Fabricated fine aggregate angularity apparatus.

From Figure 5 & Table 4, it can be stated that there is a relationship between fine aggregate angularity and gradation of the collected samples. The well graded samples only have lower values of FAA number & fell within the limit of 43 to 45 as per Nebraska Transportation Center, USA. This limit exists for the samples of Sylhet sands & Baluchora sand.



Fig. 7. Fine aggregate angularity (FAA) test in progress.

The comparison shows that the uncompacted void content or angularity number increases as the fineness of the aggregate increases and graded aggregate has lower void content than

single-sized aggregate. But result may get deflected for particle shape & particle texture (such as Chokoria, Padma river, Baluchora sand). Sylhet sands show standard value of fine aggregate angularity.

7. Conclusion

Road construction industry mostly covers with the flexible pavement construction in the world especially in Bangladesh. Fine aggregate selection having a good angularity number is very important for flexible pavement construction & may be a solution to resist rutting and permanent undulation. Good performing mixture should have designed with uncompacted void contents ranges from 43 to 45 which resulting in a larger interlock between the particles and consequently larger shear strength. Fine aggregate angularity apparatus which is inexpensive can be fabricated as per ASTM C-1252 or AASHTO T-304 manual to determine FAA. Well graded fine aggregates can be recommended to use in flexible pavement construction near the surface layer for higher traffic loads.

References

- AASHTO T-304, Uncompacted Void Content of Fine Aggregate.
- ASTMC-1252, Standard Test Methods for Uncompacted Void Content of Fine Aggregate (as Influenced by Particle Shape, Surface Texture, and Grading).
- Chowdhury Arif, Button Joe, Kohale Vipin, and Jahn David (2001); "Evaluation of super pave fine aggregate angularity specification"; RESEARCH REPORT ICAR – 201-1.
- Lee Chih-Jen, White Thomas D.& West Terry R.(1999); "Effect of fine aggregate angularity on asphalt mixture performance"; FHWA/DV/JTRP-98/20.
- Murthy V.N.S.(1989); " Geotechnical Engineering" Principles And Practice of Soil Mechanics and Foundation Engineering; Marcel Dekker,Inc.;270 Madison Avenue, New York.
- Yong-Rak Kim, (2009), "Effects of aggregate angularity on mix design characteristics and pavement performance", Nebraska transportation center, University of Nebraska-Lincoln.